

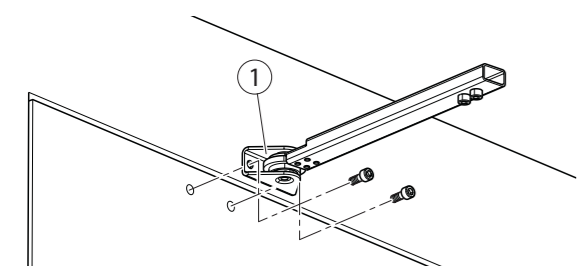

Gestänge-Lagerbock montieren

i Bei der Verwendung des Sensorgestänges separate Montageanleitung beachten.

- ▶ Gestänge-Lagerbock (1) mit 2 Schrauben festschrauben.



Gestänge montieren

Für Leibungstiefe LT 0–400 mm.

- ▶ Schrauben (3) an der Teleskopstange (1) öffnen.
- ▶ Tür in Geschlossenstellung bringen.
- ▶ Teleskopstange (1) an Tür/Türrahmen montieren.
- ▶ Hebel (2) auf der Antriebsachse ansetzen (Position gestrichelt dargestellt).

! Damit die Kronenverzahnung (5) des Hebels (2) nicht beschädigt wird, unbedingt sicherstellen, dass der Hebel (2) richtig auf der Achse angesetzt wird.

- ▶ Mitgelieferte Schraube mit mittelfestem Schraubensicherungs-lack bestreichen und mit 15 Nm anziehen.

Nur bei EMD-F:

! ▶ Die max. Hebelvorspannung beim Slimdrive EMD-F unbedingt einhalten.
Mit Adapter für Sensorgestänge ist wegen des Türöffnungswinkels <math><90^\circ</math> keine EN4-5-Montage möglich. Die Montage des Adapters siehe beiliegende Montageanleitung zum Adapter.

- ▶ Hebel (2) vorspannen, bis Teleskopstange (1) die in der jeweiligen Abbildung gezeigte Position einnimmt.
- ▶ Beide Schrauben (3) anziehen (Anzugsdrehmoment ca. 15 Nm).

Montageart: Kopfmontage Bandgegenseite

Normale Gestängemontage (EN6):

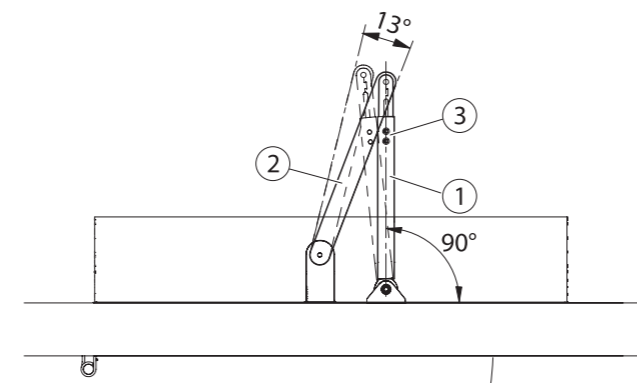

EN4-5-Montage:

- i** ▶ Bei EN4-5-Montage Gestänge um einen Zahn der Kronenverzahnung (5) versetzt montieren.
- Bei Montage des Gestänges mit Zahnversatz muss eine Montageplatte (6) montiert werden.

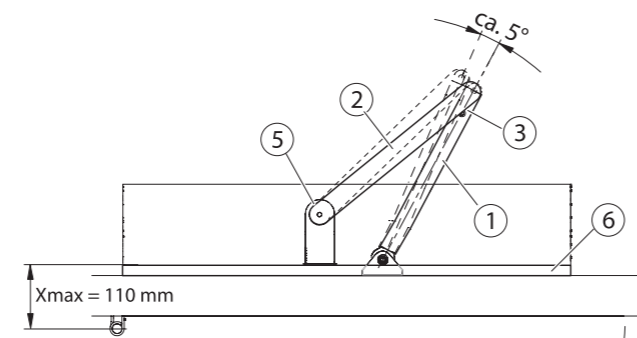

- Teleskopstange
- Hebel
- Schrauben
- Türanschlagpuffer
- Kronenverzahnung
- Montageplatte

Anschlagmaße Kopfmontage Bandgegenseite

Anschlagmaße für Montageplatte
DIN rechts/links spiegelbildlich

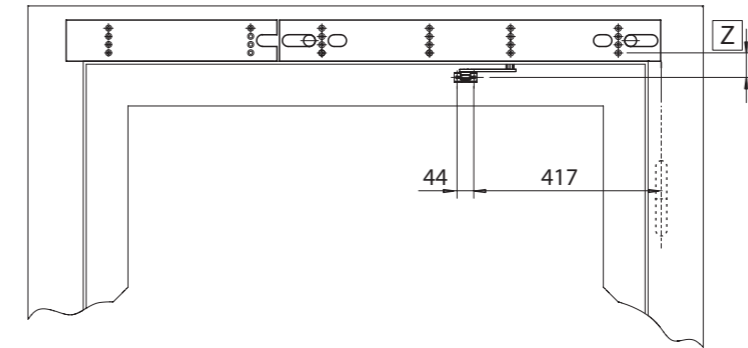

Anschlagmaße für Direktbefestigung
DIN rechts/links spiegelbildlich

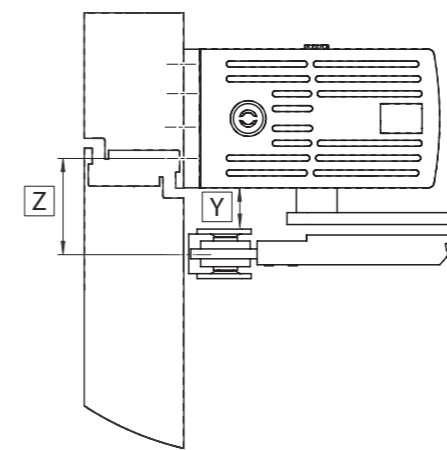
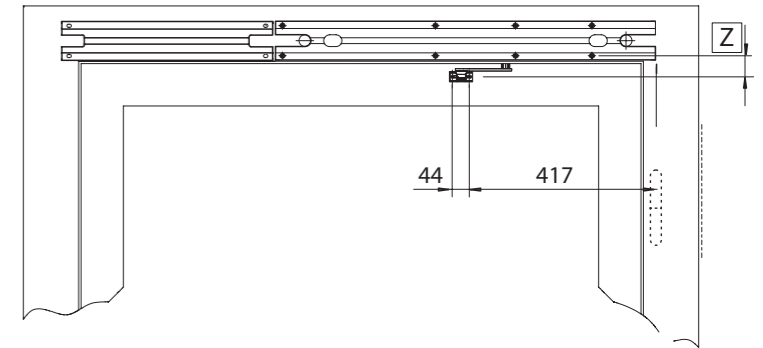

Maß Y	Grundplatte	Montageplatte
Standard	24	22
Mit Achsverlängerung	50	48

Maß Z	Grundplatte	Montageplatte
Standard	43	48
Mit Achsverlängerung	69	74

Befestigungsmittel für Gestänge

Stahl-/ Aluminiumtüren	Holztüren
2 Zylinderschrauben M6 x 20 und Einnietmuttern M6	2 Holzschrauben mit Halbrundkopf Ø5 x 50

- Germany**
GEZE GmbH
GEZE Süd-West
Tel. +49 (0) 7152 203 594
E-Mail: leonberg.de@geze.com
- Austria**
GEZE Austria
E-Mail: austria.at@geze.com
- Baltic States**
Lithuania / Latvia / Estonia
E-Mail: baltic-states@geze.com
- Benelux**
GEZE Benelux B.V.
E-Mail: benelux.nl@geze.com
- Bulgaria**
GEZE Bulgaria - Trade
E-Mail: office-bulgaria@geze.com
- China**
GEZE Industries (Tianjin) Co., Ltd.
E-Mail: chinasales@geze.com.cn
- France**
GEZE France S.A.R.L.
E-Mail: france.fr@geze.com
- Hungary**
GEZE Hungary Kft.
E-Mail: office-hungary@geze.com
- Iberia**
GEZE Iberia S.R.L.
E-Mail: info.es@geze.com
- India**
GEZE India Private Ltd.
E-Mail: office-india@geze.com
- Italy**
GEZE Italia S.r.l.
E-Mail: italia.it@geze.com
- Poland**
GEZE Polska Sp.z o.o.
E-Mail: geze.pl@geze.com
- Romania**
GEZE Romania S.R.L.
E-Mail: office-romania@geze.com
- Russia**
OOO GEZE RUS
E-Mail: office-russia@geze.com
- Scandinavia - Sweden**
GEZE Scandinavia AB
E-Mail: sverige.se@geze.com
- Scandinavia - Norway**
GEZE Scandinavia AB avd. Norge
E-Mail: norge.se@geze.com
- Scandinavia - Denmark**
GEZE Danmark
E-Mail: danmark.se@geze.com
- Singapore**
GEZE (Asia Pacific) Pte. Ltd.
E-Mail: gezesea@geze.com.sg
- South Africa**
GEZE South Africa (Pty) Ltd.
E-Mail: info@gezesasa.co.za
- Switzerland**
GEZE Schweiz AG
E-Mail: schweiz.ch@geze.com
- Turkey**
GEZE Kapi ve Pencere Sistemleri
E-Mail: office-turkey@geze.com
- Ukraine**
LLC GEZE Ukraine
E-Mail: office-ukraine@geze.com
- United Arab Emirates/GCC**
GEZE Middle East
E-Mail: gezeme@geze.com
- United Kingdom**
GEZE UK Ltd.
E-Mail: info.uk@geze.com





Type of installation: transom installation opposite hinge side

Normal link arm installation (EN6):

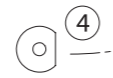
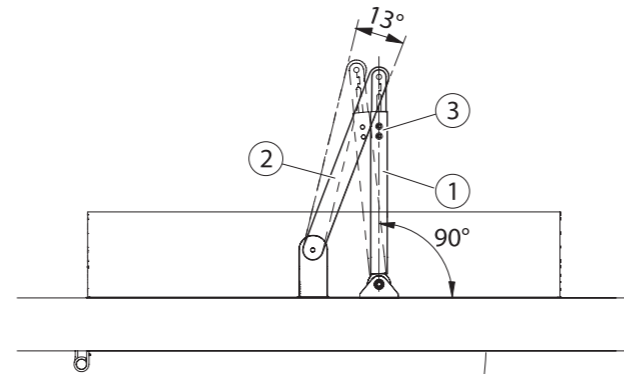

EN4-5 installation:

- i** ▶ For EN4-5 installation, install the link arm offset by one tooth of the crown gearing (5).
- For installation of the link arm with preload a mounting plate (6) must be installed.

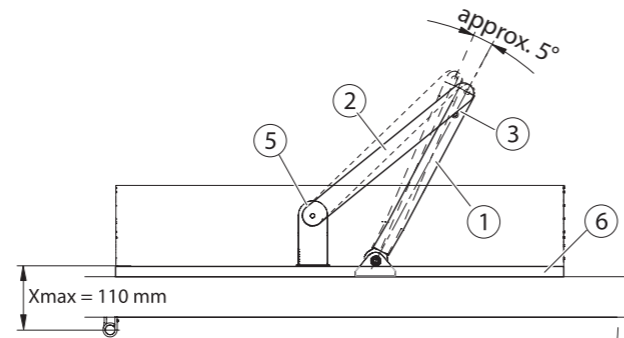

- 1 Telescopic rod
- 2 Lever
- 3 Screws
- 4 Door stop buffer
- 5 Crown gearing
- 6 Mounting plate

Fitting dimensions transom installation opposite hinge side

Fitting dimensions for mounting plate
DIN right/left mirrored

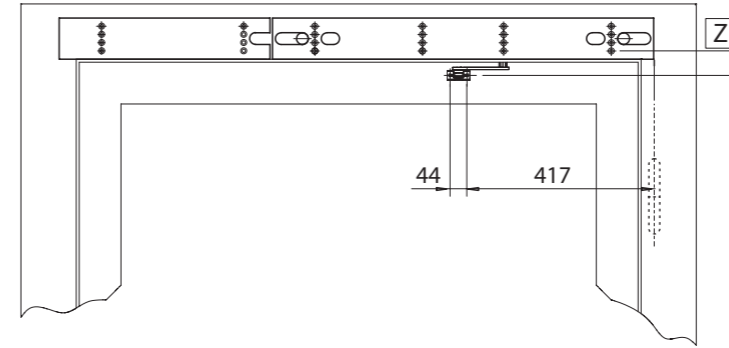

Fitting dimensions for direct attachment
DIN right/left mirrored

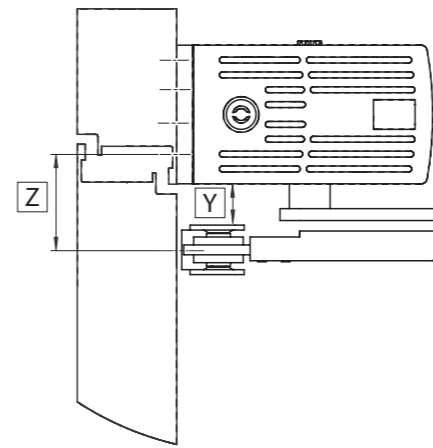
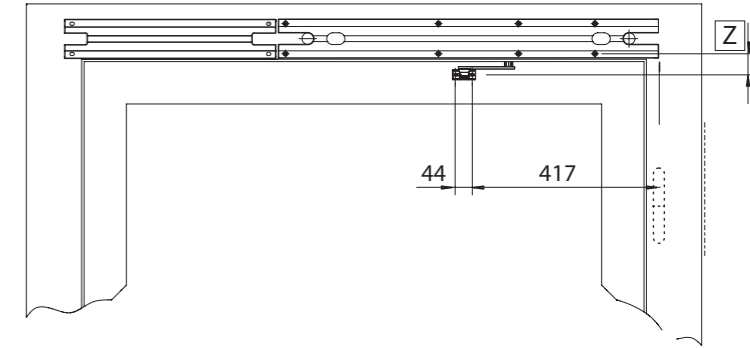

Dimension Y	Base plate	Mounting plate
Standard	24	22
With spindle extension	50	48

Dimension Z	Base plate	Mounting plate
Standard	43	48
With spindle extension	69	74

Fasteners for link arm

Steel/aluminium doors	Timber doors
2 cylinder head screws M6 × 20 and riveting nuts M6	2 wood screws with button head Ø5 × 50

Dimension Y: Upper edge of the link arm bearing block – lower edge of the drive

Dimension Z: Fixing drill hole for the link arm – lower fixing drill hole for the mounting plate/base plate

Installing the link arm bearing block

i Follow separate installation instructions in situations involving the use of the sensor link arm.

- ▶ Screw the link arm bearing block (1) on with 2 screws.

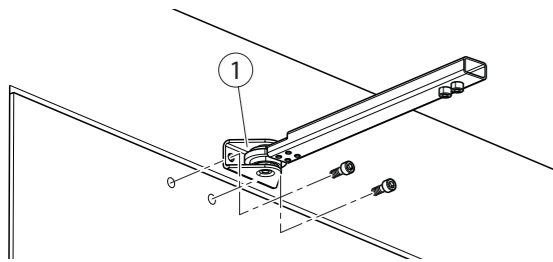

Mounting the link arm

For reveal depth LT 0–400 mm.

- ▶ Release the screws (3) on the telescope bar (1).
- ▶ Move the door to the closed position.
- ▶ Attach the telescopic rod (1) to the door/door frame.
- ▶ Set the lever (2) on the drive axle (position represented by dotted lines).

! To prevent damage to the crown gearing (5) of the lever (2), always make sure the lever (2) is inserted onto the pivot correctly.

- ▶ Coat the screw provided with medium duty screw locking paint and tighten with 15 Nm.

Only for EMD-F:

! ▶ The max. lever pre-tension for Slimdrive EMD-F must never be exceeded.
With adapter for sensor link arm no EN4-5 installation is possible because of the door opening angle being <90°. See the enclosed installation instructions for the adapter for information on installing the adapter.

- ▶ Pre-tension lever (2) until the telescope bar (1) is in the position shown in the respective illustration.
- ▶ Tighten both screws (3) (tightening torque: approx. 15 Nm).

Germany
GEZE GmbH
GEZE Süd-West
Tel. +49 (0) 7152 203 594
E-Mail: leonberg.de@geze.com
GEZE GmbH
Niederlassung Süd-Ost
Tel. +49 (0) 7152 203 6440
E-Mail: muenchen.de@geze.com
GEZE GmbH
Niederlassung Ost
Tel. +49 (0) 7152 203 6840
E-Mail: berflin.de@geze.com
GEZE GmbH
Niederlassung Mitte/Luxemburg
Tel. +49 (0) 7152 203 6888
E-Mail: frankfurt.de@geze.com
GEZE GmbH
Niederlassung West
Tel. +49 (0) 7152 203 6770
E-Mail: duesseldorf.de@geze.com
GEZE GmbH
Niederlassung Nord
Tel. +49 (0) 7152 203 6600
E-Mail: hamburg.de@geze.com

GEZE Service GmbH
Tel. +49 (0) 1802 923392
E-Mail: service-info.de@geze.com
Austria
GEZE Austria
E-Mail: austria.at@geze.com
www.geze.at
Baltic States –
Lithuania / Latvia / Estonia
E-Mail: baltic-states@geze.com
Benelux
GEZE Benelux B.V.
E-Mail: benelux.nl@geze.com
www.geze.be
www.geze.nl
Bulgaria
GEZE Bulgaria – Trade
E-Mail: office-bulgaria@geze.com
www.geze.bg

China
GEZE Industries (Tianjin) Co., Ltd.
E-Mail: chinasales@geze.com.cn
www.geze.com.cn
GEZE Industries (Tianjin) Co., Ltd.
Branch Office Shanghai
E-Mail: chinasales@geze.com.cn
www.geze.com.cn
GEZE Industries (Tianjin) Co., Ltd.
Branch Office Guangzhou
E-Mail: chinasales@geze.com.cn
www.geze.com.cn
GEZE Industries (Tianjin) Co., Ltd.
Branch Office Beijing
E-Mail: chinasales@geze.com.cn
www.geze.com.cn
France
GEZE France S.A.R.L.
E-Mail: france.fr@geze.com
www.geze.fr
Hungary
GEZE Hungary Kft.
E-Mail: office-hungary@geze.com
www.geze.hu

Iberia
GEZE Iberia S.R.L.
E-Mail: info.es@geze.com
www.geze.es
India
GEZE India Private Ltd.
E-Mail: office-india@geze.com
www.geze.in
Italy
GEZE Italia S.r.l.
E-Mail: italia.it@geze.com
www.geze.it
GEZE Engineering Roma S.r.l.
E-Mail: italia.it@geze.com
www.geze.com

Romania
GEZE Romania S.R.L.
E-Mail: office-romania@geze.com
www.geze.ro
Russia
OOO GEZE RUS
E-Mail: office-russia@geze.com
www.geze.ru
Scandinavia – Sweden
GEZE Scandinavia AB
E-Mail: norge.se@geze.com
www.geze.se
Scandinavia – Norway
GEZE Scandinavia AB avd. Norge
E-Mail: norge.se@geze.com
www.geze.no
Scandinavia – Denmark
GEZE Danmark
E-Mail: danmark.se@geze.com
www.geze.dk
Singapore
GEZE (Asia Pacific) Pte. Ltd.
E-Mail: gezesea@geze.com.sg
www.geze.com

South Africa
GEZE South Africa (Pty) Ltd.
E-Mail: info@gezesacoza
www.geze.co.za
Switzerland
GEZE Schweiz AG
E-Mail: schweiz.ch@geze.com
www.geze.ch
Turkey
GEZE Kapı ve Pencere Sistemleri
E-Mail: office-turkey@geze.com
www.geze.com
Ukraine
LLC GEZE Ukraine
E-Mail: office-ukraine@geze.com
www.geze.ua
United Arab Emirates/GCC
GEZE Middle East
E-Mail: gezeme@geze.com
www.geze.ae
United Kingdom
GEZE UK Ltd.
E-Mail: info.uk@geze.com
www.geze.com

