

**DE Drehtürantriebe
mit Gestänge
Adapter für Gestänge und
Sensor**

DE Montageanleitung
GB Mounting instructions

**GB Swing door drives
with link arm
Adapter for link arm and
sensor**



Germany GEZE Sonderkonstruktionen GmbH E-Mail: sk.de@geze.com	GEZE Industries (Tianjin) Co., Ltd. Branch Office Shanghai E-Mail: chinasales@geze.com.cn	Romania GEZE Romania S.R.L. E-Mail: office-romania@geze.com
GEZE GmbH Niederlassung Nord/Ost E-Mail: berlin.de@geze.com	GEZE Industries (Tianjin) Co., Ltd. Branch Office Guangzhou E-Mail: chinasales@geze.com.cn	Russian Federation GEZE GmbH Representative Office Russia E-Mail: office-russia@geze.com
GEZE GmbH Niederlassung West E-Mail: essen.de@geze.com	GEZE Industries (Tianjin) Co., Ltd. Branch Office Beijing E-Mail: chinasales@geze.com.cn	Scandinavia GEZE Scandinavia AB E-Mail: sverige.se@geze.com
GEZE GmbH Niederlassung Mitte E-Mail: frankfurt.de@geze.com	GEZE Industries (Tianjin) Co., Ltd. Branch Office Singapore E-Mail: gezesea@geze.com.sg	GEZE Norway E-Mail: norge.se@geze.com
GEZE GmbH Niederlassung Süd E-Mail: leonberg.de@geze.com	France GEZE France S.A.R.L. E-Mail: france.fr@geze.com	GEZE Finland E-Mail: finland.se@geze.com
GEZE Service GmbH E-Mail: service-info.de@geze.com	Hungary GEZE Hungary Kft. E-Mail: office-hungary@geze.com	GEZE Denmark E-Mail: danmark.se@geze.com
GEZE Service GmbH Niederlassung Berlin E-Mail: service-info.de@geze.com	Iberia GEZE Iberia S.R.L. E-Mail: info@geze.es	South Africa DCLSA Distributors (Pty.) Ltd. E-Mail: info@dclsa.co.za
Austria GEZE Austria GmbH E-Mail: austria.at@geze.com	India GEZE India Private Ltd. E-Mail: office-india@geze.com	Switzerland GEZE Schweiz AG E-Mail: schweiz.ch@geze.com
Baltic States GEZE GmbH Baltic States office E-Mail: office-latvia@geze.com	Italy GEZE Italia Srl E-Mail: italia.it@geze.com	Turkey GEZE GmbH Türkiye - İstanbul E-Mail: office-turkey@geze.com
Benelux GEZE Benelux B.V. E-Mail: benelux.nl@geze.com	GEZE Engineering Roma Srl E-Mail: roma@geze.biz	Ukraine Repräsentanz GEZE GmbH Ukraine E-Mail: office-ukraine@geze.com
Bulgaria GEZE Bulgaria - Trade E-Mail: office-bulgaria@geze.com	Kazakhstan GEZE Central Asia E-Mail: office-kazakhstan@geze.com	United Arab Emirates/GCC GEZE Middle East E-Mail: geze@emirates.net.ae
China GEZE Industries (Tianjin) Co., Ltd. E-Mail: Sales-info@geze.com.cn	Poland GEZE Polska Sp.z o.o. E-Mail: geze.pl@geze.com	United Kingdom GEZE UK Ltd. E-Mail: info.uk@geze.com

GEZE GmbH
P.O.Box 1363
71229 Leonberg
Germany

Tel.: 0049 7152 203-0
Fax: 0049 7152 203-310
www.geze.com

141316-00



Gestänge mit Adapter montieren / Mounting link arm with adapter

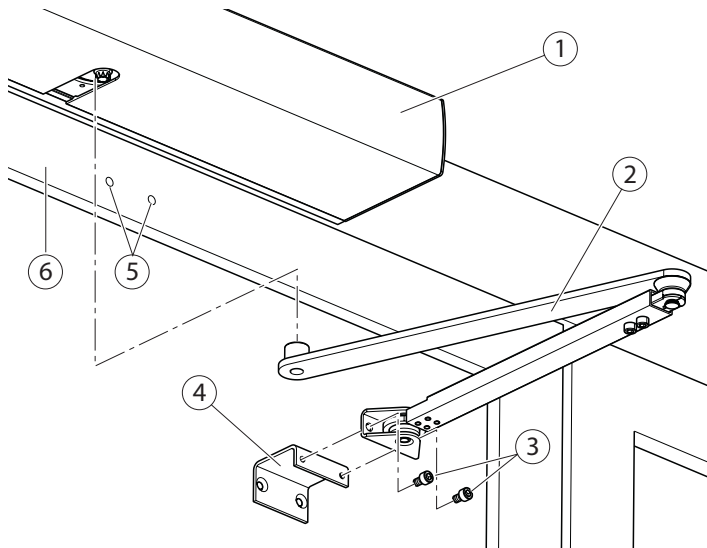

- ▶ Antrieb (1) montieren.
 - ▶ Gestänge (2) mit beiliegenden Schrauben M6 × 10 (3) mit Adapter (4) verschrauben und am Antrieb (1) montieren.
 - ▶ Gestänge (2) ausrichten und Befestigungsbohrungen (5) am Türblatt (6) anzeichnen.
 - ▶ Bohrungen / Gewinde je nach Türblatt-Ausführung setzen.
-
- ▶ Mount the drive (1).
 - ▶ Screw the link arm (2) with the enclosed screws M6 × 10 (3) to the adapter (4) and mount it onto the drive (1).
 - ▶ Align the link arm (2) and draw the fixing holes (5) at the door leaf (6).
 - ▶ Place the holes/threads as required for the respective door leaf version.

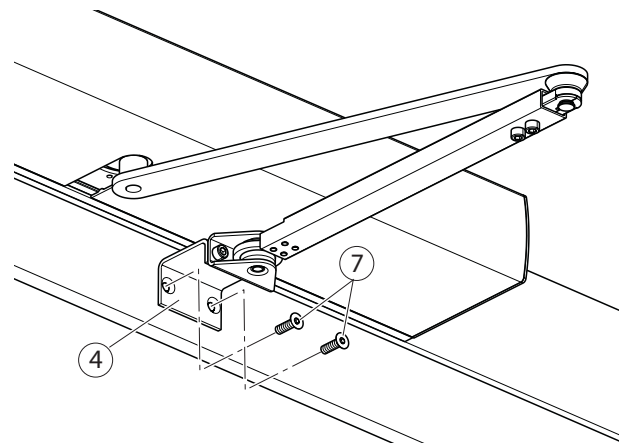

- ▶ Nur Senkkopfschrauben (6) verwenden, damit das Sensorprofil nicht auf den Schraubenköpfen aufliegt.
 - ▶ Adapter (4) mit beiliegenden Senkkopfschrauben (6) am Türblatt befestigen.
-
- ▶ Use only countersunk head screws (6) so that the sensor profile does not contact the screw heads.
 - ▶ Fasten the adapter (4) to the door leaf (6) using the enclosed countersunk head screws.

Sensorleiste ablängen / Cutting the sensor strip to length

i Wir empfehlen einen Abstand von Sensorleiste zur Türblattkante von min. 20 mm.

i We recommend a distance of at least 20 mm from the sensor strip to the door leaf edge.

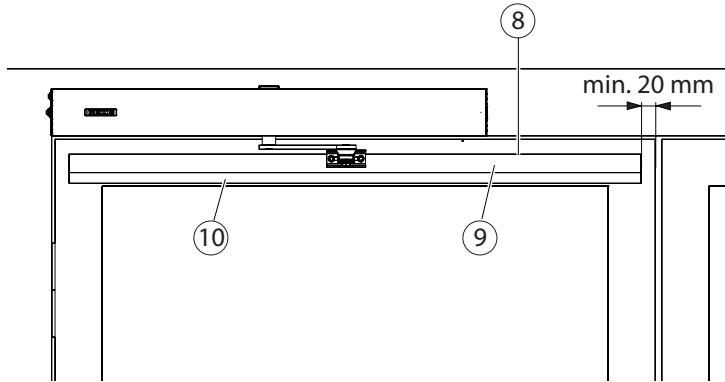

- ▶ Sensorleiste (8) entsprechend der Türblattbreite ablängen.
Sensorleiste (8) = Sensorprofil (9) + Sensorfenster (10)
- ▶ Cut the sensor strip (8) to length in accordance with the door leaf width.
Sensor strip (8) = Sensor profile (9) + Sensor window (10)

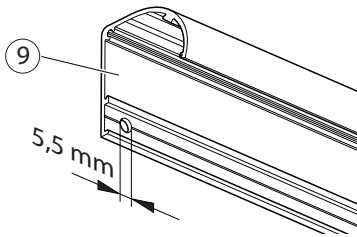

- ▶ Bohrungen Ø 5,5 mm für Befestigungsschrauben in Sensorprofil (9) bohren.
- ▶ Drill the holes Ø 5.5 mm for fastening screws in the sensor profile (9).

Sensorprofil festschrauben / Screwing on the sensor profile

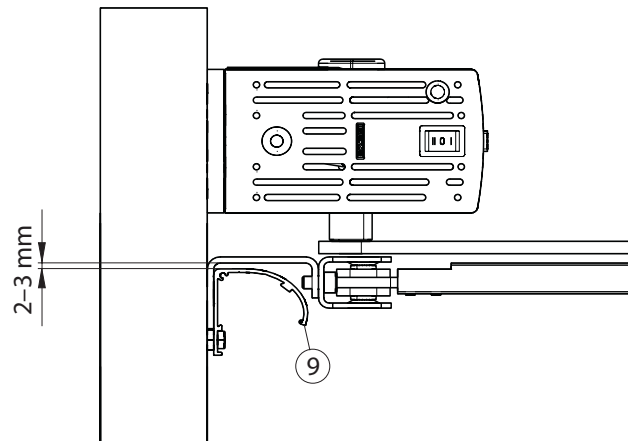

- ▶ Sensorprofil (9) ausrichten und Bohrungspositionen (13) auf Türblatt übertragen.
- ▶ Align the sensor profile (9) and mark the hole positions (13) on the door leaf.

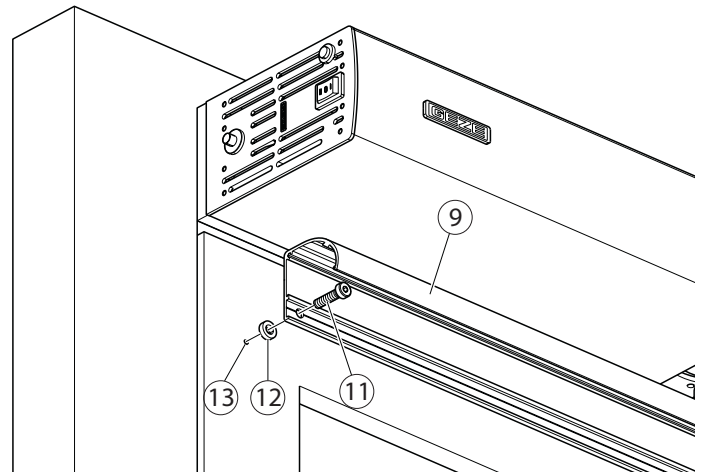

- ▶ Beiliegende Distanzscheiben (12) unterlegen und Sensorprofil (9) mit Befestigungsschrauben (11) festschrauben.
- ▶ Insert the enclosed spacers (12) and screw on the sensor profile (9) using the fastening screws (11).