

135479-02

GEZE

159976-... www.geze.de



i

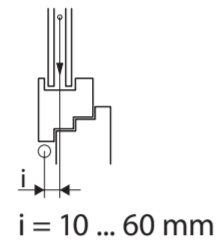
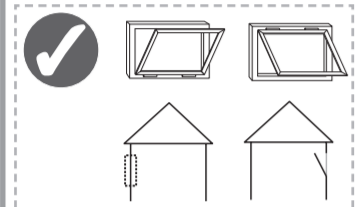

a [mm]	a [mm]	a [mm]	max. [kg/m ²]	max. [kg]	
< 1200	-	-	20	60	1
< 2400	< 2400	-	20	60	2
< 3000	< 2700	< 2700	20	60	3
< 1100	-	-	25	60	1
< 2200	< 2200	-	25	60	2
< 2700	< 2400	< 2400	25	60	3
< 1000	-	-	30	60	1
< 2000	< 2000	-	30	60	2
< 2200	< 2000	< 1700	30	60	3

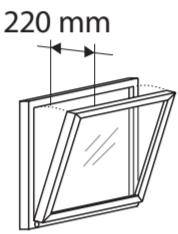

i+ 40445-EP-02

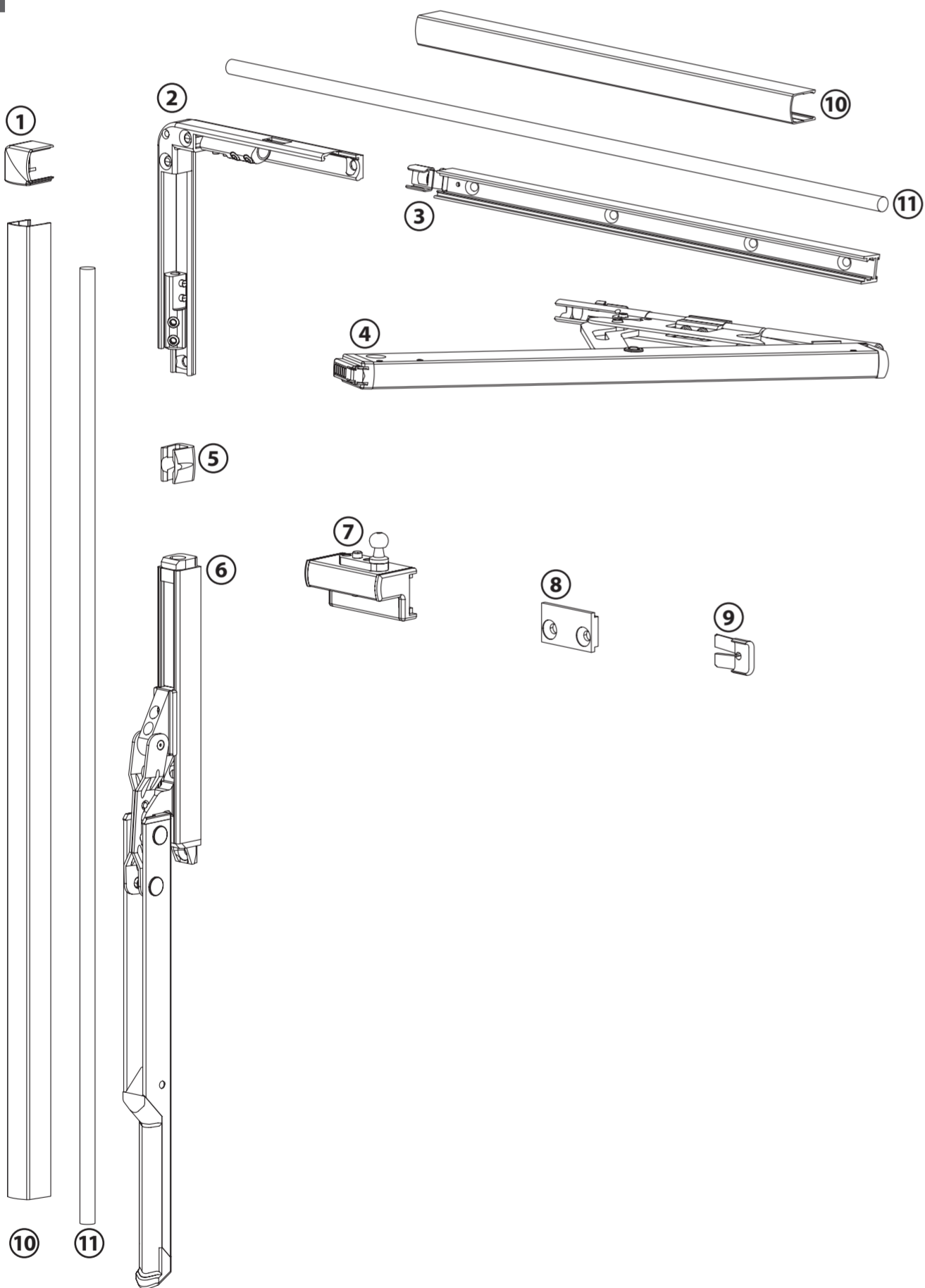

3 mm 12 mm $\varnothing 2,5 \text{ mm}$ $\varnothing 3,5 \text{ mm}$



4 x 35 DIN 97 / DIN 7997 $\varnothing 2,5 \text{ mm}$
 min. 1,8 mm 4,2 x L DIN 7972 / DIN 7982 $\varnothing 3,5 \text{ mm}$
 min. 2 x 4,2 x L DIN 7972 / DIN 7982 $\varnothing 3,5 \text{ mm}$

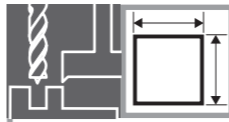

a [mm]	f1 [mm]	f2 [mm]	f3 [mm]	b [mm]	D min. [mm]	Y [mm]
440 ... 480	$a/2 + D - 50$	-	-	350 ... 400	18	D + 9
480 ... 1200	$a/2 + D - 30$	-	-	401 ... 450	16	D + 9
940 ... 2400	min. 180	$a/2 + 32$	-	451 ... 600	14	D + 9
1530 ... 3000	$a/4 + D - 120$	$a/3 - 7$	$a/3 - 7$	> 601	12	D + 9

